

Jardin urbain

Oasis



| Materials & Finishes

Steel structure th. 8 mm anti-corrosion treatment and hot-lacquered, RAL or AkzoNobel colors of your choice
Adjustable feet (adjustment on a maximum height of 120 mm)
Slats seat in laminated wood th. 8 mm, 4 colors at your choice (Light Afro, Afro Sahara, English Cherry, Sun Pear)
Aluminium planting liner th. 2 mm

| Fixing

To put on the ground

| Option

Lifting hooks for planting liner

Seat standard colors



SEAT

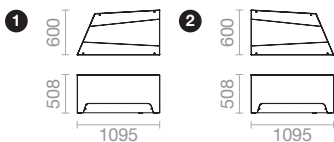

Weight: 36 kg

PLANTER

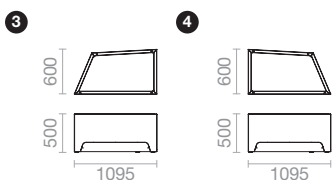

Substrate vol.: 150 l.
Water vol.: 20 l.
Weight: 42 kg

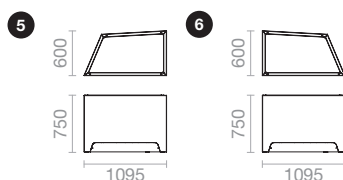

Substrate vol.: 240 l.
Water vol.: 32 l.
Weight: 58 kg

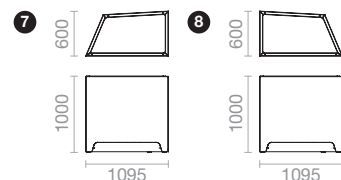

Substrate vol.: 282 l.
Water vol.: 37 l.
Weight: 72 kg

Urban garden

Oasis



Other layout: 5-8-6-2-6

| Materials & Finishes

Steel structure th. 8 mm anti-corrosion treatment and hot-lacquered, RAL or AkzoNobel colors of your choice
Adjustable feet
Slats seat in laminated wood th. 8 mm, 4 colors at your choice (Light Afro, Afro Sahara, English Cherry, Sun Pear)
Aluminium planting liner th. 2 mm

| Fixing

To put on the ground

| Option

Lifting hooks for planting liner

Seat standard colors



(A) 7-6-6-1

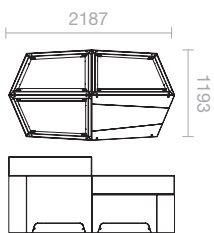

(B) 2-6-2-6-2

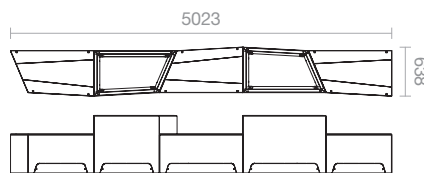

(C) 1-2-6-8-7-6-2-1

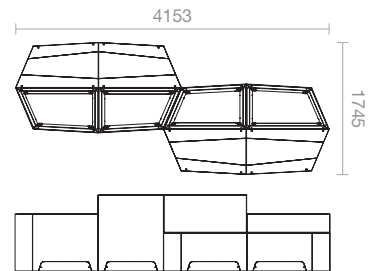

(D) 5-8-5-8-5-8-2-1-2-1-2-1

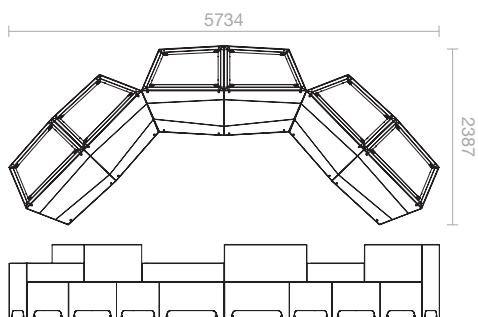

(E) 2-4-8-7-3-1-1-3-5-6-4-2

